

Multi-port RS-232 to Ethernet Data Gateway

Installation Guide

1. Introduction

Thank you for purchasing this multi-port RS-232 to Ethernet data gateway. It provides an ideal solution to control RS-232 serial devices over a TCP/IP based Ethernet.

Features:

- ✓ Provides 4 RS-232 Ports over Ethernet
- ✓ Provides 4 DB9 RS-232 Male Connectors
- ✓ RS-232 Speed from 300bps to 115.2Kbps
- ✓ Provides one 10/100Mbps, RJ45 LAN Port
- ✓ LAN Supports Auto Cross Over Feature
- ✓ Supports Setup and Connect Passwords
- ✓ Supports Standard Windows Socket Protocol
- ✓ Provides TCP Server, TCP Client, and UDP
- ✓ Equipped with Wall Mounting Holes

2. Connector Layout

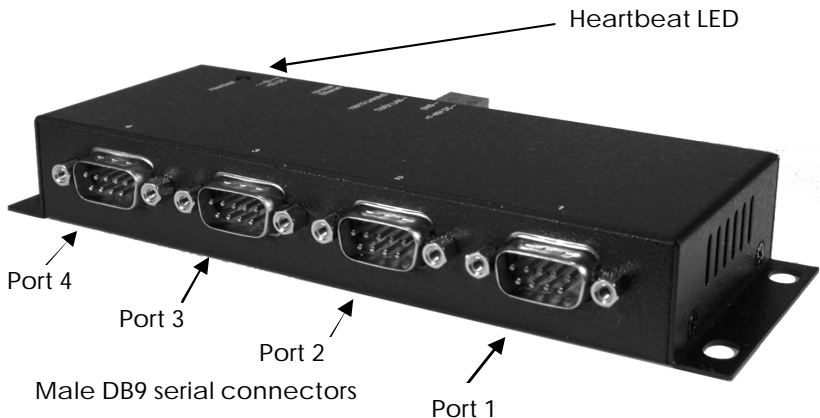

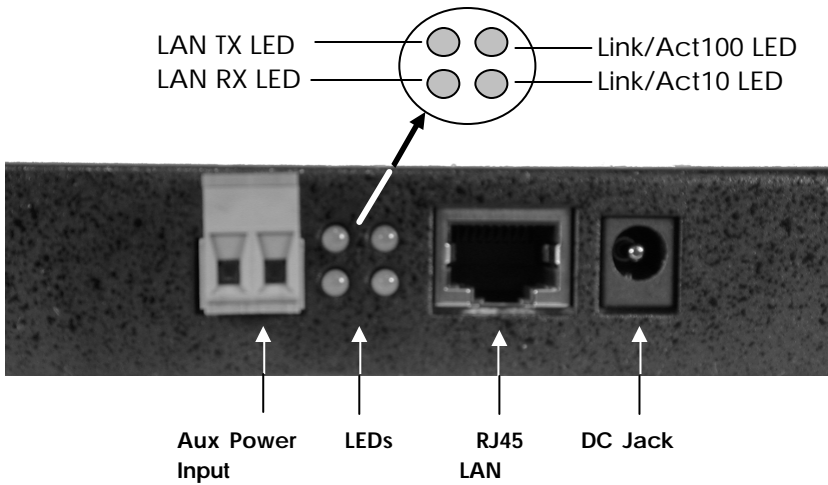

- **DC Jack Power Connector:** A DC5V/2A AC adapter is supplied with this product.
- **RJ45 Ethernet Connector:** 10/100Mbps Ethernet port. It supports auto cross-over feature. You can use the same cable to connect to either a Hub/Switch or a host computer.
- **LED Indicators:** The data gateway's top panel has a heartbeat LED and its rear panel has 4 LAN LEDs. They are described as the following table:

LED Name	Color	LED Function
Heartbeat	Green	Blinking: Normal operation Else: Malfunction
Link/Act 100	Green	Steady on: Linked in 100Mbps mode. Blinking: Transferring data
Link/Act 10	Green	Steady on: Linked in 10Mbps mode. Blinking: Transferring data
LAN TX	Green	Blinking: Sending data out to LAN port
LAN RX	Green	Blinking: Receiving data from LAN port

3. Hardware Installation

1. **Use static electricity discharge precautions.**
Remove possible static discharge potential from any objects that the data gateway may come in contact with before installation. This can be accomplished by touching a bare metal chassis rail after you have turned off the power.
2. **Attached the power adapter.**
3. **Connecting LAN cable:** Use a standard straight-through Ethernet cable to connect to a Hub or Switch. If you connect the data gateway to your computer's Ethernet port instead, you don't need to change to a cross-over type cable since the data gateway provides auto cross-over feature.
4. **Connect the data gateway's serial ports to your serial devices.**
5. **Use the wall mounting Kit if you to place the data gateway on the wall.**

4. Data Gateway Setup

Setting IP Address

Please consult your Network Administrator to determine the appropriate IP address. The IP address can be set in any of the following ways:

- Automatically from a DHCP Server
- Web Browser
- Ethernet Managing utility (Em.exe supplied by this product)

The data gateway comes with factory installed IP address **192.168.1.254**. It is ready to accept a new IP address from a DHCP Server. If your network has a DHCP server, it will

automatically assign an IP address to the data gateway the first time it is connected and powered up.

1. **Setting the IP address from a DHCP Server**

A DHCP server will automatically assign an IP address (dynamic address) as well as Subnet Mask and Gateway to this product. If you power up the data gateway without a fixed (static) IP address, the DHCP server will be able to assign an IP address (this is the default setting, **Enable DHCP**).

If you will set the IP address using another method, the address becomes static. This was done when you **Disable** the DHCP setting in the Setup Menu of the data gateway.

2. **Setting the IP address using Web Browser**

Run your browser and access the data gateway by entering the default (**192.168.1.254**) or current IP address into your browser's address window. Enter the password (default has no password). Then go to change your IP address as well other parameters if required.

3. **Setting the IP address using Em.exe Utility**

The Em.exe is a Microsoft Windows based utility to find all the data gateways connected on the same subnet and network segment. To run the Em.exe utility, please insert the driver CD supplied with the data gateway. Open (double click) the program at the following location (assume the CD-ROM drive is at E)

E:\Utility\82500\Em.exe



Data Gateway Setup

When you entered Setup Menu of the data gateway, the following page will be available for your access. Please click Update button after you changing your settings. Please also remember you password because you need it when you are going to enter this setup menu next time.

Controller Setup

IP address	169.254.95.79	
Subnet mask	255.255.255.0	
Gateway address	10.0.0.254	
Network link speed	Auto	
DHCP client	Enable	
Socket port of HTTP setup	80	
Destination IP address / socket port (TCP client and UDP)	0.0.0.0	0
Packet mode of serial input	Disable	
Device ID	1	
Report device ID when connected	Disable	
Setup password		
Access password		
Serial Port 1		
Socket port	100	TCP Server
Interface	RS 232	
Baud rate, parity, data and stop bits	9600	None 8 1
Serial Port 2		
Socket port	101	TCP Server
Interface	RS 232	
Baud rate, parity, data and stop bits	9600	None 8 1
Serial Port 3		
Socket port	102	TCP Server
Interface	RS 232	
Baud rate, parity, data and stop bits	9600	None 8 1
Serial Port 4		
Socket port	103	TCP Server
Interface	RS 232	
Baud rate, parity, data and stop bits	9600	None 8 1
Keyboard Input		
Socket port	104	TCP Server

Update

5. Male DB9 Pin Assignments and Cable Wiring

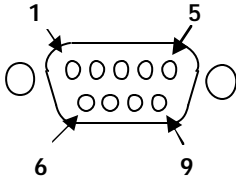

<u>9 Pins</u>	<u>Signal</u>
1	DCD
2	RXD
3	TXD
4	DTR
5	GND
6	DSR
7	RTS
8	CTS
9	NC

DB9(Male) to DB9(Male) Wiring

<u>DB9 (Gateway)</u>		<u>DB9 (Serial Device)</u>
1 DCD	←	1 DCD
2 RXD	←	2 RXD
3 TXD	→	3 TXD
4 DTR	→	4 DTR
5 GND	←	5 GND
6 DSR	→	6 DSR
7 RTS	←	7 RTS
8 CTS	→	8 CTS

6. Environmental Specifications

Power requirements:	5V DC, 250mA (max)
Operating temp.:	0 to 55°C (32 to 131°F)
Operating humidity:	5 to 95% RH
Dimensions (LxWxH):	5.90" (L)x2.61" (W)x1.02" (H) (15.00 x 6.65 x 2.60 cm)

